

# **User Manual Book Combination Hob**

**Combinato Series**  
BK 1725, BK 1731

# TABLE OF CONTENTS

SAFETY WARNINGS	4
Safety Warnings	4
Operation and Maintenance	4
Important Safety Instructions	5
NAME OF PARTS	8
BK 1725	8
BK 1731	9
INSTALLATION	10
Installation Instructions	10
Selecting installation equipment	10
Before Locating The Fixing Brackets	12
Connecting the Hob to the Power Supply	13
HOW TO USE	16
Before Using Your New Hob	16
Using the Touch Controls	16
Choosing the Right Cookware	16
To start cooking	18
Activating Cooking Zone	23
Cooking Guidelines	27
MAINTENANCE	30
Cleaning The Hob Surface	30
Glass/Ceramic Surface	30
Hints and Tips	31
Maintenance of the Hob	32
TROUBLESHOOTING	34

PRECAUTION	35
SPECIFICATION	36

This guide book explains everything you need to know about your new product. Please contact our Customer Care should you need further assistance through [www.modena.com](http://www.modena.com)

# SAFETY WARNINGS

## Safety Warnings

Your safety is important to us. Please read the following information carefully before installing or using your Hob.

### Installation Warnings

#### Electrical Shock Hazard

- Disconnect the appliance from the electricity supply before carrying out any work or maintenance on it.
- Make sure that grounding system is installed properly.
- Alterations to the domestic wiring system must only be made by MODENA Technician.
- Failure to follow this advice may result in electrical shock or death.

### Cut Hazard

- Take care - panel edges are sharp.
- Failure to be cautious could result in injury or cuts.

### Important Safety Instructions

- No combustible material or products should be placed on the appliance at any time.
- In order to avoid a hazard, this appliance must be installed according to these instructions for installation.
- This appliance is to be properly installed and grounded only by MODENA Technician by contacting MODENA Customer Service.
- This appliance should be connected to a circuit which incorporates an isolating switch providing full disconnection from the power supply.
- Failure to install the appliance correctly could invalidate any warranty or liability claims.

## Operation and Maintenance

### Electrical Shock Hazard

- Do not cook on a broken or cracked hob. If the hob surface break or crack, switch the appliance off immediately at the mains power supply (wall switch) and contact MODENA technician.

- Switch the hob off at the wall before cleaning or maintenance.
- Failure to follow this advice may result in electrical shock or death.

### Health Hazard

- This appliance complies with electromagnetic safety standards.
- However, persons with cardiac pacemakers or other electrical implants (such as insulin pumps) must consult with their doctor or implant manufacturer before using this appliance to make sure that their implants will not be affected by the electromagnetic field.
- Failure to follow this advice may result in death.

### Hot Surface Hazard

- During usage, accessible parts of this appliance will become hot enough to cause burns.

#### **ATTENTION**

Metallic objects such as knives, forks, spoons and lids should not be placed on the hob surface since they might get hot.

- Do not let your body, clothing or any item other than suitable cookware contact the ceramic glass until the surface is cooled down.
- Keep children away from the appliance.
- Handles of saucepans may be hot to touch. Check saucepan handles, do not overhang other cooking zones that are on. Keep handles out of reach of children.
- Failure to follow this advice could result in burns and scalds.

### Cut Hazard

- The razor-sharp blade of a hob scraper is exposed when the safety cover is retracted. Use with extreme care and always store safely and out of reach of children.
- Failure to be cautious could result in injury or cuts.

## **Important Safety Instructions**

- Never leave the appliance unattended when in use. Boil over causes smoke and greasy spillovers may ignite fire.

- Never use your appliance as a work or storage surface.
- Never leave any objects or utensils on the appliance.
- Do not place or leave any magnetisable objects (e.g. credit cards, memory cards) or electronic devices (e.g. computers, MP3 players) near the appliance, as they may be affected by its electromagnetic field.
- Never use your appliance for warming or heating the room.
- After use, always turn off the cooking zones and the hob as described in this manual (i.e. by using the touch controls). Do not rely on the pan detection feature to turn off the cooking zones when you remove the pans.
- Do not allow children to play with the appliance or sit, stand, or climb on it.
- Do not store items of interest to children in cabinets above the hob. Children climbing on the hob could be seriously injured.
- Do not leave children alone or unattended in the area where the appliance is in use.
- Do not repair or replace any part of the appliance unless specifically recommended in the manual. All other repairing process should be done by MODENA technician.
- Do not use steam cleaner to clean hob.
- Do not place or drop heavy objects on hob.
- Do not stand on your hob.
- Do not use pans with jagged edges or drag pans across the ceramic glass surface as this may scratch the glass.
- Do not use scourers or any other harsh abrasive cleaning agents for cleaning, as these can scratch the ceramic glass.
- If the power supply cable is damaged, it must only be replaced by MODENA technician.
- This appliance is intended to be used in household and similar applications such as: staff kitchen areas in shops, offices and other working environments; farm houses; by clients in hotels, motels and other residential type environments; bed and breakfast type environments.
- This appliance can be used by children aged from 8 years and above and persons with reduced physical, sensory or mental capabilities or lack of experience and knowledge if they have been given supervision or instruction concerning use of the appliance in a safe way and understand the hazards involved. Children shall not play with

the appliance. Cleaning and user maintenance shall not be done by children without supervision.

**WARNING!**

- Unattended cooking on a hob with fat or oil can be dangerous and may result in fire. NEVER try to extinguish fire with water, but switch off the appliance and then cover flame with a lid or a fire blanket.
- The appliance is not intended to be operated by means of an external timer or separate remote-control system.

## NAME OF PARTS

### BK 1725

1. Induction Zone
2. Vitroceramic Burner Dual Zone
3. Ceramic Glass
4. Control panel of cooking zone 1
5. Control panel of cooking zone 2

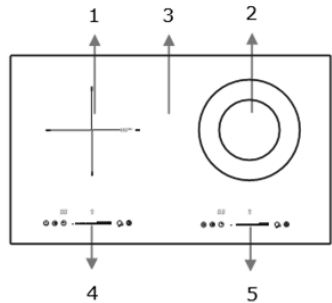

### Control Panel

1. Booster function /Extended zone control buttons
2. Stop & Go control buttons
3. Timer control button
4. Heating level/Timer adjusting slider
5. Child Lock control button
6. ON/OFF button

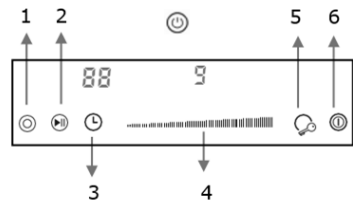



# BK 1731

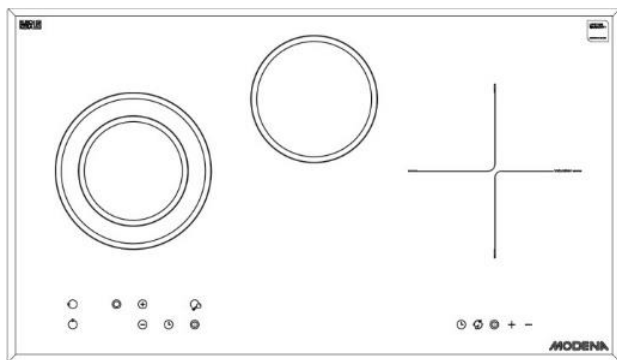

	ON/OFF button		Timer button
	PLUS button		Lock button
	MINUS button		Double Zone button**
	Burner position button		Temperature (C) or Power (W) button

# INSTALLATION

## Installation Instructions

The appliance must be installed and connected in accordance with current regulations.

After unpacking the appliance, ensure there is no visible damage. If it has been damaged during transit, DO NOT USE, contact where you buy immediately.

Please contact MODENA Call Center for installation.

## Selecting installation equipment

- Cut out the work surface according to the measurements shown in the picture.
- For the purpose of installation and use, a space minimum of 5 cm shall be preserved around the hole.
- Be sure the thickness of the work surface is at least 30mm. Please select heat-resistant work surface material to avoid larger deformation caused by the heat radiation from the hotplate. As shown below:

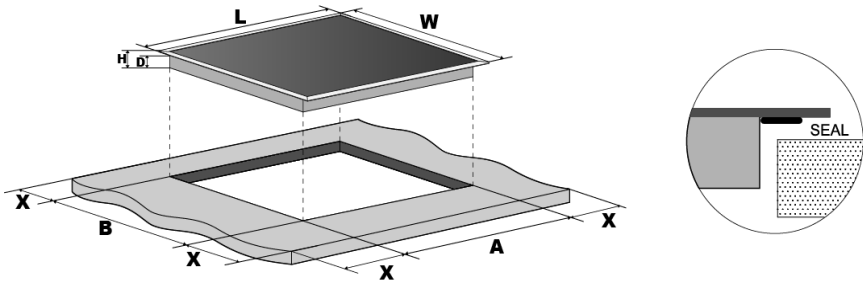

Model	L ( mm )	W ( mm )	A ( mm )	B ( mm )	D ( mm )
BK 1725	730	430	705	405	58
BK 1731	730	420	718	398	65

## ATTENTION

- If the induction cooker is installed with an oven below it, separator panel must be placed between the bottom of the stove and the frame below it at a minimum distance of 10 cm.
- If the induction cooker is installed without oven on the bottom, the minimum distances to put the separator panel is 15 cm.
- Electrical cable from both equipments must be installed separately to avoid short circuit.

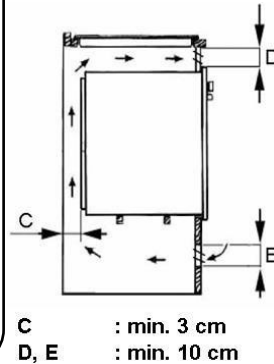

A (mm)	B (mm)	C (mm)	D	E
760 mm	50 mm minimal	20 mm minimal	Air intake	Air exit 5mm

Under any circumstances, make sure the electric hob is well ventilated and the air inlet and outlet are not blocked. Ensure the electric hob is in good work state. As shown below:

## NOTE:

The safety distance between the hotplate and the cupboard above the hotplate should be at least 760mm.

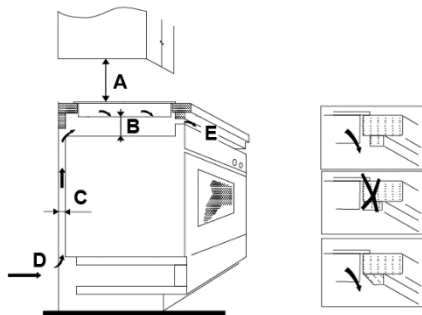

## Before Locating The Fixing Brackets

The unit should be placed on a stable, smooth surface (use the packaging). Do not apply force onto the controls protruding from the hob.

### Easy Fit Kits

There is one easy fit kits package for each hob, include fixing clips and screws (for ceramic hob there are total 2pcs clip and 2pcs screw, for induction hob there are total 4pcs clip and 4pcs screw). Find the easy fit kit package first.

#### Fix Clips to Hob:

Insert the fixing clip into fixing hole reserved on sides of housing, fix clip to housing with screw, then insert hob into cabinet/work surface.

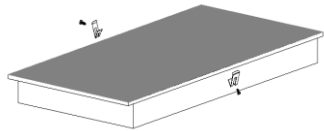
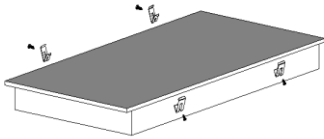

#### Fix Hob to Cabinet:

Insert the hob into the cabinet/work surface as below diagrams, the mounted clips on the sides can secure your hob sturdily.

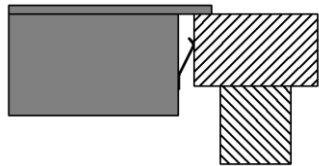
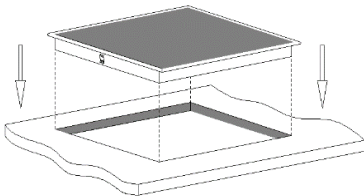

## Installing the Induction Cooker on Kitchen Set Table

To install an induction cooker on the kitchen counter niche, follow these instructions:



The cable is directly plugged into a power supply through a circuit breaker.

### **ATTENTION:**

Do not use a power plug, if it is branched/paralleled with other appliances.

Post the seal adhesive along the sides of the stove's bottom part to maintain humidity in the bottom area of the induction cooker.



Place the induction cooker on the kitchen counter niche, and use the available clamp from the induction cooker packaging to fasten the screws.

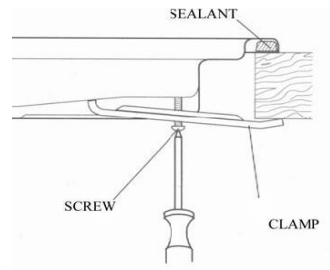

Make sure all parts have been installed and fastened and plug the stove power cord into the power outlet.

## Connecting the Hob to the Power Supply

The power supply should be connected in compliance with the relevant standard, or a single-pole circuit breaker. The appliance have a large power rating and must be connected to electricity by MODENA Technician.

## NOTES:

- If the cable is damaged or needs replacement, this should be done by MODENA technician using the proper tools, so as to avoid any accidents.
- If the appliance is being connected directly to the mains supply, an omnipolar circuit breaker must be installed with a minimum gap of 3mm between the contacts.
- The installer must ensure that the correct electrical connection has been made and that it complies with safety regulations.
- The cable must not be bent or compressed.
- The cable must be checked regularly and only replaced by MODENA technician.

The method of connections shown below.

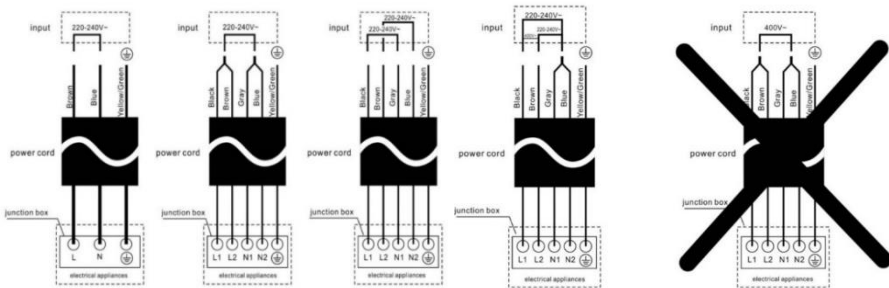

### **CAUTIONS:**

- The hob must be installed by MODENA technicians. Please never conduct the operation by yourself.
- The electric hob shall not be mounted next to cooling equipment, dishwashers and tumble dryers.
- The electric hob shall be installed properly to ensure better heat radiation and enhance its reliability.
- The wall and induced heating zone above the work surface shall withstand heat.
- To avoid any damage, the sandwich layer and adhesive must be heat resistant.
- Do not use steam cleaners.
- This electric hob can be connected only to a supply with system impedance no more than 0.427 ohm. In case necessary, please consult your supply authority for system impedance information.

## HOW TO USE

### Before Using Your New Hob

- Read this guide, taking special note on the 'Safety Warnings' section.
- Remove any protective film that may still be on your new electric hob.

### Using the Touch Controls

- The controls respond to touch, so you don't need to apply any pressure.
- Use the ball of your finger, not its tip.
- You will hear a beep each time a touch is registered.
- Make sure the controls are always clean, dry, and that there is no object (e.g. a utensil or a cloth) covering them. Even a thin film of water may make the controls difficult to operate.

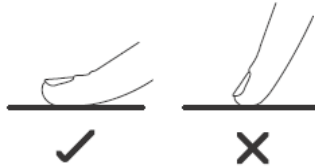

### Choosing the Right Cookware

- Only use cookware with a base suitable for induction cooking. Look for the induction symbol on the packaging or on the bottom of the pan.
- You can check whether your cookware is suitable by carrying out a magnet test. Move a magnet towards the base of the pan. If it is attracted, the pan is suitable for induction hob.
- If you do not have a magnet:
  - Put some water in the pan you want to check.
  - If  does not flash in the display and the water is heating, the pan is suitable.
- Cookware made from the following materials is not suitable for an

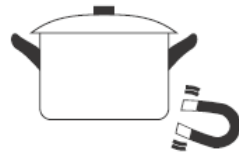



induction hob: pure stainless steel, aluminium or copper without a magnetic base, glass, wood, porcelain, ceramic, and earthenware.

- Induction hobs are made from smooth, ceramic glass, the heat comes from a magnetic induction coil which heats the cookware but not the cooking surface. The heat from the cookware is transferred to the food.
- It's important that you use only metal pans specifically designed and/or approved for use on induction hobs. Never allow melamine or plastic containers to come in contact with the heat zones.

Do not use cookware with jagged edges or a curved base.



Make sure that the base of your pan is smooth, sits flat against the glass, and is the same size as the cooking zone. If you use smaller pot efficiency could be less than expected. Always centre your pan on the cooking zone.

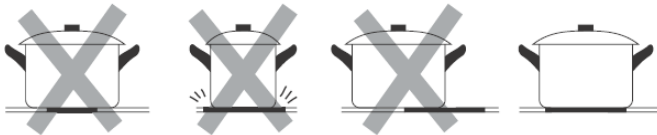

Always lift pans off the electric hob—do not slide, or they may scratch the glass.

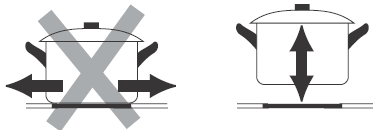

**CAUTIONS:**

You can use any kind of pot or pan for Ceramic Hob. Make sure that base of your pot or pan is smooth, sits flat against the ceramic glass, and same size as the cooking zone for better cooking performance.

## To start cooking

1. After the hob be connected to electricity and power on.  
Press and hold the ON/OFF  control button for about 3 seconds until you hear a “beep” to turn the hob on. Now the hob enters Standby mode, all heat setting indicators and Timer setting indicators shows “-”.
2. Place a suitable pan on the cooking zone that you wish to use.  
Make sure the bottom of the pan and the surface of the cooking zone are clean and dry.
3. Touch the heating zone selection control button to select and activate the cooking zone.
4. Set heating level of cooking zone
  - You can adjust heat setting by touching the slider control.

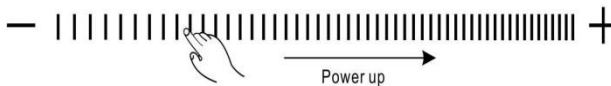

### CAUTIONS:

- After connecting to electricity, when power on, the buzzer of hob beeps once, all indicators lights up for 1 second then off.
- You can modify the heat setting at any time during cooking. The heating element will turn off under power level 0, with indicator shows “-”
- The heat setting indicator of the selected zone will flash when adjusting. After adjusting, the number in indicator will flash for 5 seconds and then stop flash, then the setting has been confirmed.
- When the hob is in Standby mode, if there is no actions within 1 minute, the electric hob will auto turn off, with buzzer beeps once.

## To Turn Hob Off

1. Adjust heat setting to 0 level, which indicator shows “-”.
2. You can also turn the whole hob off by touching the ON/OFF  control button.

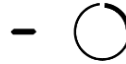

### **NOTES:**

- If there is power outage during cooking, all programmed settings will be cancelled, you need to reset the programme again.
- The cooling fan of induction hob will remain on for about 1 minute after the hob is turned off.

## Beware Of Hot Surfaces

After turn off, the letter **H** will show in the power setting indicator if cooking zone is hot to touch. It will disappear when the surface has cooled down to a safe temperature.

When in Standby mode, if the surface of cooking zone is hot to touch, the letter “H” and “-” will show in its heat setting indicator alternately.

### **NOTES:**

This can also be used as an energy saving function: if you want to heat further pans, use the hotplate that is still hot.

## Using Booster Function – Induction Hob

For induction hob models which with Booster function, you can use the “Booster” function to boost power of relevant cooking zone for a maximum power rating for 5 minutes. This function could reduce the cooking time, which convenience for cooking when in hurry!

## To use booster function when induction hob is working, follows below:

1. Turn on the hob by touch ON / OFF control button.

2. Touch the Booster function control button

**B**, the heating zone indicator will show **b** and flashing for 5 seconds then stop flashing. Then Booster function is activated, the power reach Maximum strength for 5 minutes, and then return to the pre-set heat setting.

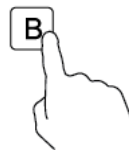

3. To turn off Booster function:

- When in Booster function, touch the “Booster” control button again, you can deactivate Booster function.
- You can also cancel Booster function by adjusting power level setting.

#### **NOTES:**

After booster finish, the cooking zone will return to previously power level setting before booster.

### Child Lock

- You can lock the controls to prevent unintended use (for example children accidentally turning the cooking zones on) by activate Child Lock function.
- When the controls are locked, all other touch control buttons will be disabled except the ON/OFF control button and Child Lock control button.

To lock the controls



Touch the Child Lock control button  once . The timer indicator will show “Lo”, and Child Lock function is activated.

To unlock the controls

1. Make sure the electric hob is turned on.
2. Touch and hold the Child Lock control button  for 3 seconds, the buzzer beeps once and “Lo” disappears in timer indicator, the Child Lock is deactivated.

You can now start using your electric hob.

### **WARNING:**

Under the child lock mode, all controls button are disabled except the ON/OFF  and child lock . You can always turn the hob off with the ON/OFF  control in an emergency, but you shall unlock the hob first in the next operation

### **NOTES:**

Under Child Lock function, if you turn the hob off, the Child Lock function will still be activated. If you want to turn on the hob after that, you need to deactivate Child Lock function first.

## Stop & Go Function

- **Make cooking easy!** When cooking, your doorbell rings, phone rings, or kid shouts from another door. Need to step out of kitchen? These means dinner could burn, or take longer time to ready if you switch everything off.
- The **Stop & Go function** can turn off all zones. When you back, with touching of the button once more , hob restarts where they were, to continue cooking.

## Activate Stop & Go function

To activate **Stop & Go** function, you can press the **Stop & Go** function button once. Then all programmed setting be hold on and hob stop heating, all heat setting indicators show "P".

## Deactivate Stop & Go function

To cancel **Stop & Go** function, you can press the **Stop & Go** function again, after come back. Then all programmer setting will return to what they were, Stop & Go indicator "P" disappear from all indicators.



When **Stop & Go** function activated, all control buttons are disable except the ON/OFF and Stop & Go button.

## NOTES:

The hob will auto turn off, if Stop & Go function last more than 10 minutes.

## Using Timer

When the hob is turned on, you can use the timer in two different ways: You can use it as a minute minder. In this case, the timer will not turn any cooking zone off when the set time is up.

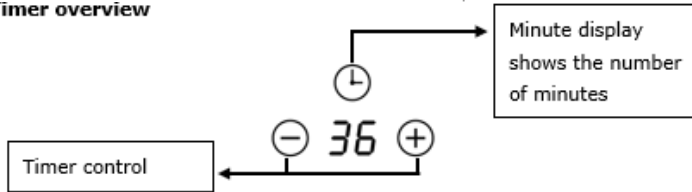

- You can set the minute minder/timer for up to 99 minutes.

### Timer overview



## Using the Timer as a Minute Minder

If you have not selected any cooking zones

1. Touch the timer control button , the number in **10**  indicator flashing. 
2. Then Adjust Minute Minder Setting

- Touch the timer control button  once, the single digit number in timer indicator will flashes, then adjust single digit of minute minder setting by sliding the slider control.
- Press the timer control button again, the number of tens digit in timer indicator flashing, then adjust tens digit of minute minder setting by sliding the slider control.

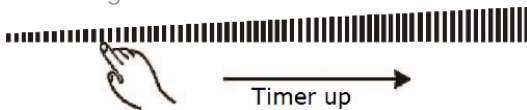

### NOTES:

- If for 10 minutes there are no selected cooking zone, the appliance will be automatically turned off.
- Use the cooking utensil with an even bottom and the diameter which fits the cooking zone.
- The maximum weight of cooking utensil and the cooking material is 10 kg.

## Activating Cooking Zone

To activate the cooking zone, put the cooking utensil directly on the center of the cooking zone area before turning on the induction cooker.

Touch the ON/OFF power icon for 3 seconds to activate the cooking zone. It is indicated the display will turn on.



Select the cooking zone by touching the position icon in accordance with the cooking zone to be activated on the control panel.



**To increase / decrease the heat in the activated cooking zone:**

Touch and hold the plus (+) sign to increase the heat or the minus (-) to decrease the heat . It is marked by the numbers on the control panel (1 to 9).



**To deactivate the cooking zone:**

Touch the minus (-) icon until the LED display on the control panel is turned off or Touch the ON/OFF icon.



**To lock the operation system:**

To activating the lock function, touch the lock icon until the indicator light above the lock is turned on.

To deactivate the lock function, touch the lock symbol again until the indicator light is turned off.



### To Set The Timer:

If you have not selected any cooking zones

1. Touch the timer control button , the number in timer indicator flashing.



2. Then Adjust Minute Minder Setting

• Touch the timer control button  once, the single digit number in timer indicator will flashes, then adjust single digit of minute minder setting by sliding the slider control.

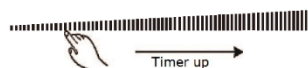

• Press the timer control button again, the number of tens digit in timer indicator flashing, then adjust tens digit of minute minder setting by sliding the slider control.

#### **NOTES:**

By continuously touching the timer control button, the timer slider works at this order: "Single Digit-Tens Digit-Confirm-timer setting-Single Digit-..."

3. When the minute minder is set, it will begin to count down immediately, the display will show the remaining time.

4. Buzzer will beep for 30 seconds and timer indicator shows "--"when the setting time finished.



Set the Timer to Turn Cooking Zone Off



1. Touch the timer control button once, the number of single digit in timer indicator flashing, then adjust single digit of timer setting by sliding the slider control.



2. Press the timer control button again, the number of tens digit in timer indicator flashing, then adjust tens digit of timer setting by sliding the slider control.

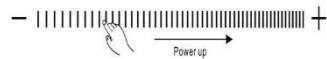

3. After adjusting, the setting in timer indicator will be flashing for 5 seconds and then stop flashing, then the setting has been confirmed.

**NOTES:**

When the timer indicator flashes, if you touch timer control button once more, you can quick confirm the timer setting.

3. When the time is set, it will begin to count down immediately, the display will show the remaining time.

**NOTES:**

By continuously touching the timer control button, th works at below order: "Single Digit-Tens Digit-Confirm Single Digit-..."



4. When cooking timer expires, the corresponding cooking zone will be switched off automatically.

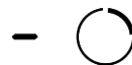

**NOTES:**

If indicator shows timer setting of cooking zone. To check minute reminder setting, press the timer control button, the indicator will show minute reminder setting.

**NOTES:**

The default setting of minutes reminder and timer is 30 minutes

### Detection of Pan and Small Articles



For induction hob, if the display flashes " in heat setting indicator, it means that:

- you have not placed a pan on the correct cooking zone, or
- the pan you're using is not suitable for induction cooking, or
- the pan is too small or not properly centered on the cooking zone.

**NOTES:**

- No heating takes place unless there is a suitable pan on the cooking zone.
- The hob will auto turn off after 2 minutes if no suitable pan is placed on it.
- When an unsuitable size or non-magnetic pan (e.g. aluminum), or some other small item (e.g. knife, fork, key) is left on the hob, the hob automatically go to standby in 1 minute. The fan will keep cooking down the induction hob for a further 1 minute.

### Residual Heat Warning

When the hob has been operated for some time, there will be some residual heat. The letter "H" appears to warn you to keep  

### Auto Shutdown

Another safety feature of the hob is auto shutdown. This occurs whenever you forget to switch off a cooking zone. The default shutdown times shown in table below:

Power level	1	2	3	4	5	6	7	8	9
Default working time (hour)	8	8	8	4	4	4	2	2	2

### Over – Heat Protection

The equipped temperature sensor can monitor the temperature inside the hob. When an excessive temperature is sensed, the hob will stop the operation automatically.

### Over – Flow Protection

For your safety, the programme will auto shut off the power if liquid boiling or touch control panel is covered with wet cloth. All control buttons will be inactive except ON/OFF and Child Lock button, unless you wipe the touch control area dry.

## **Cooking Guidelines**

### Cooking Tips

- When food comes to the boil, reduce the power setting.
- Using a lid will reduce cooking times and save energy by retaining the heat.
- Minimize the amount of liquid or fat to reduce cooking times.
- Start cooking on a high setting and reduce the setting when the food has heated through.

### Simmering, cooking rice

- Simmering occurs below boiling point, at around 85°C, when bubbles are just rising occasionally to the surface of the cooking liquid. It is the key to delicious soups and tender stews because flavors develop without overcooking the food. You should also cook egg-based and flour thickened sauces below boiling point.
- Some tasks, including cooking rice by the absorption method, may require a setting higher than the lowest setting to ensure the food is cooked properly in the time recommended.

### Searing steak

To cook juicy flavorsome steaks:

1. Stand the meat at room temperature for about 20 minutes before cooking.
2. Heat up a heavy-based frying pan.

3. Brush both sides of the steak with oil. Drizzle a small amount of oil into the hot pan and then lower the meat onto the hot pan.
4. Leave the steak to rest on a warm plate for a few minutes to allow it to relax and become tender before serving.
5. Only turn the steak once during cooking. The exact cooking time will depend on the thickness of the steak and doneness. Times may vary from about 2 – 8 minutes per side. Press the steak to check how cooked it is – the firmer it feels the more ‘well done’ it will be.

### For stir-frying

1. Choose a ceramic compatible flat-based wok or a large frying pan.
2. Have all the ingredients and equipment ready. Stir-frying should be quick. If cooking large quantities, cook the food in several smaller batches.
3. Preheat the pan briefly and add two tablespoons of oil.
4. Cook any meat first, put it aside and keep it warm.
5. Stir-fry the vegetables. When they are hot but still crisp, turn the cooking zone to a lower setting, return the meat to the pan and add your sauce.
6. Stir the ingredients gently to make sure they are heated through.
7. Serve immediately.

### Heat Settings

The settings below for induction hob are guidelines only. The exact setting will depend on factors including your cookware and the amount of food you are cooking. Experiment with the induction hob to find the settings that suit you best.

Heat setting	Suitability
1 - 2	<ul style="list-style-type: none"> <li>• delicate warming for small amounts of food</li> <li>• melting chocolate, butter, and foods that burn quickly</li> <li>• gentle simmering</li> <li>• slow warming</li> </ul>
3 - 4	<ul style="list-style-type: none"> <li>• reheating</li> <li>• rapid simmering</li> <li>• cooking rice</li> </ul>
5 - 6	<ul style="list-style-type: none"> <li>• pancakes</li> </ul>

7 - 8	<ul style="list-style-type: none"><li>• sautéing</li><li>• cooking pasta</li></ul>
9	<ul style="list-style-type: none"><li>• stir-frying</li><li>• searing</li><li>• bringing soup to the boil</li><li>• boiling water</li></ul>

## MAINTENANCE

### **IMPORTANT!**

Before any maintenance or cleaning work is performed, disconnect the appliance from electricity supply and ensure the appliances is completely cool.

### **Cleaning The Hob Surface**

Clean spillages from the hob surface as soon as possible after use. Always ensure the surface is cool enough before cleaning.

Use a soft cloth or kitchen paper to clean the surface. If the spillage has dried on the surface, you may need to use a specialist vitro-ceramic glass cleaner, which is available in most supermarkets.

Do not use other abrasive cleaners and/or wire wool ect., as it may scratch the ceramic glass surface of your hob.

The MODENA Induction cooker is designed specifically for long term usage and does not require complicated maintenance. However, there are several advices on how to maintain the quality of your stove.

### **Glass/Ceramic Surface**

Clean the dirty part of the glass/ceramic using a wet cloth or a special glass/ceramic cleaner, and then dry it using a soft cloth.

### ATTENTION!

- Glass/ceramic must be cleaned under cool condition, unless stained with sugar or liquid with high content of sugar, in which case the glass/ceramic must be immediately cleaned, (be careful when doing this, as there's a risk of burn).
- Always turn off the cooking zone and unplug the power cord from the power outlet when necessary before cleaning your induction cooker.
- Do not use any cleaning agent that can damage the glass/ceramic.
- Use a fine cloth and avoid scratching your glass/ceramic.

## Hints and Tips

Problem	Recommended Action	Important notice
Everyday soiling on glass (fingerprints, marks, food stains or non-sugary spillovers on the glass)	<ol style="list-style-type: none"><li>1. Switch off the power supply.</li><li>2. Apply a vitro-ceramic glass cleaner while the glass is still warm (but not hot!)</li><li>3. Rinse and wipe dry with a clean cloth or paper towel.</li><li>4. Switch on the power supply to the hob.</li></ol>	<ul style="list-style-type: none"><li>• When the power supply is disconnected from the hob, there will be no 'hot surface' indication but the cooking zone may still be hot! Take extreme care.</li><li>• Heavy-duty scourers, some nylon scourers and harsh/abrasive cleaning agents may scratch the glass. Always read the label to check if your cleaner or scourer is suitable.</li><li>• Never leave cleaning residue on the hob glass surface: it may stain the glass.</li></ul>

Problem	Recommended Action	Important notice
Boil over, melts, and hot sugary spills on the glass	<p>Remove these immediately with a fish slicer, palette knife or razor blade scraper suitable for ceramic glass of hob, but beware of hot cooking zone surfaces:</p> <ol style="list-style-type: none"> <li>1. Switch off the power supply.</li> <li>2. Hold the blade or utensil at a 30° angle and scrape the soiling or spill to a cool area of the hob.</li> <li>3. Clean the soiling or spill up with a dish cloth or paper towel.</li> <li>4. Follow steps 2 to 4 for 'Everyday soiling on glass' above.</li> </ol>	<ul style="list-style-type: none"> <li>• Remove stains left by melts and sugary food or spillovers as soon as possible. If left to cool on the glass, they may be difficult to remove or even permanently damage the glass surface.</li> <li>• Cut hazard: when the safety cover is retracted, the blade in a scraper is razor-sharp. Use with extreme care and always store safely and out of reach of children.</li> </ul>
Spillovers on the touch controls	<ol style="list-style-type: none"> <li>1. Switch off the power supply.</li> <li>2. Soak up the spill</li> <li>3. Wipe the touch control area with a clean damp sponge or cloth.</li> <li>4. Wipe the area completely dry with a paper towel.</li> <li>5. Switch on the power supply to the hob.</li> </ol>	<ul style="list-style-type: none"> <li>• The hob may beep and turn itself off, and the touch controls may not function while there is liquid on them. Make sure you wipe the touch control area dry before turning the hob back on.</li> </ul>

## Maintenance of the Hob

If you find something goes wrong for your hob, before contact the service or where you purchased it, please check whether below:

1. There is no power to the appliance:
  - Check whether there is a power cut of your department;
  - Check whether the appliance is been connected to electricity properly;
  - Has the timer setting elapsed;
  - Whether it reaches the longest cooking time setting and auto shut off;



- Whether there is liquid boiling over touch control panel and overflow protection devices auto shut off;
2. The touch control panel buttons can't be active:
    - Whether it's under "Child Lock", which there is "Lo" shows in timer displayer;
    - Whether liquid/wet cloth over touch control panel active overflow protection;
  3. After cooking there is "H" shows on display:
    - This is normal. The hob is with Residual Heat Warning safety features. It will remain on until the surface is cool enough for touch.
  4. After turn off, the fan of induction hob remains working for a while:
    - This is normal, this is to help appliances completely cool down.
  5. Some pans make crackling or clicking noises during use of induction hob:
    - This is normal, it's the sound of induction coils during working, and for different construction of your cookware, the clicking might be slightly different.
  6. The glass is being scratched:
    - Check whether you use unsuitable cookware, like rough-edged cookware.
    - Check whether unsuitable, abrasive scourer or cleaning products being used.

## TROUBLESHOOTING

If an abnormality comes up, the induction hob will enter the protective state automatically and display corresponding protective codes:

<b>Problem</b>	<b>Possible cause</b>	<b>Recommended Action</b>
E1/E2	Abnormal supply voltage	Please check whether power supply is normal, Power on after the power supply is normal.
E3	High temperature of the pan sensor	Check whether no liquid in pan, fill with liquid then restart.
E5	High temperature of the IGBT temperature sensor	Please restart after the induction hob cools down.

<b>The induction cooker is inoperable</b>	<ul style="list-style-type: none"> <li>Is the power cord plugged correctly?</li> <li>Is there electricity running through the power outlet?</li> <li>Is the cable on the unit disconnected?</li> </ul>
<b>Cooking zone is not functioning</b>	<ul style="list-style-type: none"> <li>Is the power outlet or cord properly plugged?</li> <li>Make sure the cooking zone symbol is selected and the heat is set to your needs.</li> </ul>

For all other error codes, switch off and call MODENA Call Center.

## PRECAUTION

- Always reduce the heat in the cooking zone or turn off the cooking zone before removing your cooking utensil.
- Oil or fat must be treated with caution during the cooking process since the material is flammable at certain temperature.
- After the induction cooker is done cooking, the indicator lamp (H) will still be on until the entire cooking zone is cooled off. Do not touch the cooking zone if the indicator lamp is still on.
- Avoid power cord wiring extension.
- In the case of an anomaly on your induction cooker, turn off the unit and unplug the power cable from the power outlet and immediately contact the MODENA Call Center.
- Turn off the stove or turn off the power through the MCB every after cooking is finished or when the induction cooker is not used for an extended period of time.
- Routinely service your stove once every 3 (three) months so that any anomaly on your gas stove can be immediately fixed.

## SPECIFICATION

MODEL	BK 1725	BK 1731
Type	Electric Hob ( Induction + Vitreoceramics Hob )	Electric Hob ( Induction + Vitreoceramics Hob )
Number of Burners	2	3
Burner Composition	Ø210 mm (2000 W) Ø138 – 230 mm (1100/2200 W)	Ø120-180 mm, Vitroceramics (700/1700W)
Blocking Security System	Yes	Ø140 mm Vitroceramics (700/1700W)
Color	Black	Ø200 mm Induction (2000W)
Touch control panel	Yes	Yes
Program / Timer	Digital	Black
Lock System	Yes	Yes
Electricity (Volt)	220-240	Digital
Electric frequency (Hz)	50-60	Yes
Dimension (P x L x T) mm	730 x 430 x 60	220-240
Cut off Dimension (P x L) mm	705 x 405	50-60

To improve product quality, design and specifications above might change without notice. Pictures in this manual book is scematic and might be different with the actua product. Values written in the label or in attached documentation is obtained from laboratorium according to relevant standard. Values may vary according to operational condition and appliance's conditions.

